



Liva 8G. Shown with Stovax curved log holder.



“Quality First”

OUR WAY OF THINKING

Quality speaks its own language and has its own style. You know it instinctively; you can see it, hear it and feel it.

This is the feeling we are striving for when you experience our woodburning stoves and fires for the first time. We want you to appreciate the flames, the clean combustion, the thickness of the glass, the reassuring sound when you open and close the doors and the above all, the stylish, ingenious design.

We believe that a stove must burn as efficiently as possible whilst ensuring the lowest possible CO2 emissions. They must be durable and solid, and have a functional and elegant design.

Taking this as our starting point, we have developed and manufactured stoves and fires for more than 35 years. And this is why they heat thousands of homes across Europe.



THE BENEFITS OF WOODBURNING

All Lotus stoves and fires are designed for woodburning only. Wood is an environmentally friendly fuel; when burnt, the carbon dioxide released into the atmosphere is approximately the same as that absorbed by the tree during growth. Wood is also a renewable resource, particularly when derived from plantations and cultivated woodland.



For optimum results, we recommend logs should be seasoned for 2 years or more to achieve a moisture content below 20%. This will not only give twice the output of freshly felled timber but will also help to avoid a build up of tar in your flue. Furthermore, if you can obtain hardwood logs this is better still, as they will have a greatly increased calorific value compared to softwoods.

KAARE SØLVSTEN // M.A.A, M.D.D, PAR

A Danish architect with a flair for designing woodburning stoves.

In 2001, Lotus started collaborating with architect and cabinetmaker Kaare Sølvsten. His passionate commitment and simple, stylish mode of expression has characterised the design aspect of the company in close collaboration with our engineers and manufacturers.

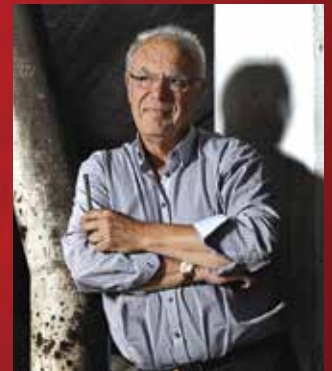

With a professional depth and competence both within the tradition of Danish craftsmanship and his training in architecture at the School of Arts and Crafts as well as the School of Architecture at the Danish Academy of Fine Arts in Copenhagen, Kaare Sølvsten's work has been awarded numerous prizes and he has gained recognition as one of the country's pre-eminent architects.

Kaare Sølvsten has a genuine love for craftsmanship and materials, and this shines through in the stoves he has designed for Lotus. He believes that quality is inextricably linked to the union of functionality, technology and design. He takes a holistic approach to his work, thinking in terms of the whole rather than a series of fragments put together. This is reflected in the Lotus design process, which endeavours to take all conditions and needs into account.

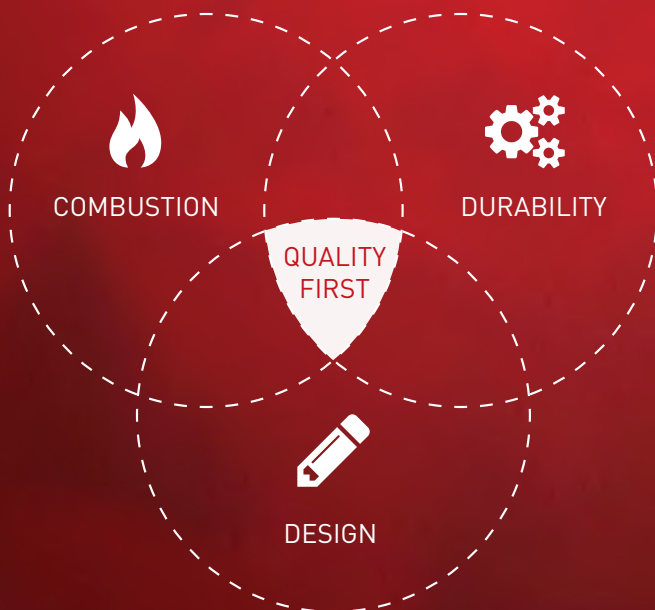

“Complete Peace of Mind...”

5 YEAR EXTENDED WARRANTY

When you choose a Lotus stove or fire, quality and technology are assured. Accordingly, your Lotus Expert Retailer will provide you with a Two Year Warranty for your new woodburning stove or fire.

This can then be extended to a Five Year Warranty provided your stove or fire is registered with Lotus. Please note, these warranties exclude certain consumable parts. Stoves or fires purchased outside of Lotus' Expert Retailer Network will carry a standard 12 Month Non-extendable Warranty. Full warranty terms & conditions are available to view at www.lotusfires.com.



EXPERT RETAILER NETWORK

We take great care to ensure that our stoves and fireplaces are designed, tested and manufactured to the highest possible quality and safety standards. We are just as concerned to make certain that they are sold and installed correctly so that you enjoy years of pleasure from your purchase.

Accordingly, you will find our products are only available from experienced, independent retailers who will be happy to show you a selection of models locally in their showrooms, often fully operational. These independent retailers will discuss your individual requirements both technical (such as sizing the heat output to your room and advising on your chimney system) and design, and ensure that you select the most appropriate product for your home. They will also be able to advise on or assist with the installation process as well as help provide any after-sales support and servicing of your appliance that you may require in the future.

Whilst we encourage our retailers to promote fireplace products and their outlets via the internet, we do not believe suitable levels of customer care and satisfaction can be obtained from nationwide online sales and we would strongly recommend that you consider this when undertaking your research and making a purchasing decision. Further, please be aware that we do not offer technical support (beyond our statutory responsibilities) to products bought via nationwide online sales, where this support would normally be offered by one of our qualified, independent retailers.

Furthermore, Lotus stoves and fires purchased from within our Expert Retailer Network will have the additional benefit of a greatly extended warranty period, subject to terms and conditions. Full details can be found at www.lotusfires.com.

THE LOTUS RANGE

Sola.....	08
Liva.....	10
Mira.....	12
Prio.....	14
Mondo.....	16
Jubilee 35.....	18
Prestige Integra.....	20
M2ST.....	22
Living.....	24
Living Base.....	26
Living Cube.....	28
Insert Fireplaces.....	30
H370.....	32
H470.....	34
H470W.....	36
H570, H570W & H570T.....	38
H700.....	40
Beto Surround.....	42
Unico Insert Fireplaces.....	44
Unico 10.....	45
Unico 11 & 12.....	46
Unico 13.....	48



SYMBOL KEY

- Nominal Heat Output
- Heat Output Range
- Efficiency





“ Lotus Comfort Eco Boost ”

The innovative Comfort Eco Boost feature makes it even easier to light a Lotus stove, and is an optional extra available on the Sola, Liva, Mira and Prestige Integra models. When activated, a boost of air is supplied to the stove's firebox, speeding up the initial ignition as well as ensuring that newly added logs take even less time to catch fire. Featuring an integrated timer, the Comfort Eco Boost automatically closes the air supply after the preset period of time has passed, meaning that you can recline in comfort and relaxation after lighting or refuelling your Lotus stove.



- 1 Air is pulled through the vent below the stove and fed directly into the firebox through the Comfort Eco Boost function
- 2 A gentle pull of the automatic handle opens the Comfort Eco Boost to supply air for the preset period of time
- 3 The Comfort Eco Boost is powered by an easily changeable 9V battery which rarely requires replacing.
- 4 The easy to use timer control allows airflow to be preset to be provided for 1-7 minutes.

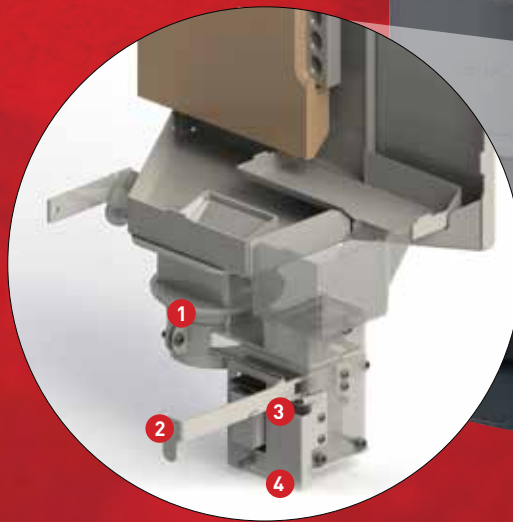

“ Approved for Smoke Control Areas ”

Most town and city homes in the UK are located in Smoke Control Areas as designated by the Clean Air Act 1993. To burn logs on a stove in these locations, the model installed must have been granted exemption from the regulations by the government through DEFRA.

This exemption is given only to appliances which have been independently tested to demonstrate particularly clean burning combustion. All Sola, Liva, Mira and Mondo stoves along with the H370 cassette fire are approved for use in Smoke Control Areas and this is shown on each product page. Your Lotus retailer can give you further help and advice.



“ Lotus Sola ”

HEATING FROM WITHIN

The Lotus Sola is a sleek and elegant stove with a tall door which makes for a fantastic experience of the flames. The stainless steel door handle follows the curved form of the door, with the ash pan concealed behind the door.

Its circular shape and depth of just 38.5 cm make it easy to integrate into many places in the home.

There are two models available; the Sola Steel and the new Sola Indian Night Stone.

🔥 5kW 🔁 3 - 7 kW Ⓜ 80%



INDIAN NIGHT STONE DETAIL:



MODELS AVAILABLE:



Sola Steel



Sola Indian Night Stone









“ Lotus Liva ”

A RANGE OF EXCEPTIONAL CHOICES

Liva stoves offer a broad range of styles and options, incorporating a number of innovative features such as a soft-close door mechanisms, a cool-to-touch door handle and easy to use air control. There is also the option of upgrading Liva stoves with Lotus's unique Comfort Eco Boost (see page 7) as well as the built-in option of an external air supply to minimise internal drafts.

Presenting a choice of high, medium and low height models to suit a range of interiors, the Liva stove collection even includes the wall mounted 8G for greater installation flexibility*. All Liva stoves are available with side windows for a panoramic flame view, with both 5 and 6 models also offered with steel sides. For ultimate versatility, the 7G can be rotated 180° thanks to its innovative pedestal base and flue connection which feature ball bearings for easy movement, allowing you to angle the stove to face different parts of the room

*Optional wall-mounting bracket required.
Also see images on pages 2 and 6

🔥 5 kW

🔄 3 - 7 kW

📊 E 78%



MODELS AVAILABLE:



Liva 5



Liva 5G



Liva 6



Liva 6G



Liva 7G



Liva 8G (Wall Hung)





“Lotus Mira”

REFINED DESIGN

The result of Danish technical expertise and innovation, Mira stoves provides a generous 5kW heat output at up to 78% efficiency. Displaying all of Lotus' hallmarks, these stylish stoves combine advanced combustion systems, user-friendly design and quality craftsmanship. For even greater convenience, Mira stoves can be upgraded with Lotus' Comfort Eco Boost (see page 7) which speeds up ignition and automatically reduces airflow once the fire is burning.

The Mira series includes models such as the 4, which features large side windows, as well as the 7 which has the option of Lotus' PowerStones upgrade for long lasting heat even after the fire has gone out.

 5 kW

 3 - 7 kW

 78%



MODELS AVAILABLE:



Mira 3



Mira 4



Mira 7

“Lotus Prio”

A COSY HEAT SOURCE

The Lotus Prio series presents the best of fine Danish design and craftsmanship.

With a subtly curving form and generous flame picture in the door, the Prio is as generous in its aesthetic appeal as in its impressive heat output. There is a concealed compartment beneath that has space for storing kindling and accessories. The Prio 6 features side-viewing windows for an enhanced 180° view of the flames.

🔥 6 kW 🔁 3 - 8 kW Ⓜ 79%

MODELS AVAILABLE:



Prio 5 Steel



Prio 5 Soapstone



Prio 6 Steel



Prio 6 Soapstone



Prio 6 Steel



“Lotus Mondo”



ELEGANCE AND EFFICIENCY

The Lotus Mondo series represents simple design and fine craftsmanship, apparent in the detail. The Mondo 1 has a clean straight front, whereas the Mondo 2 offers the added appeal of a gently curving front. Both models feature an elegant curved door handle.

Mondo 1 and 2 are both available as 'S' models with complete soapstone covering on the sides and top which stores and radiates heat.



🔥 5 kW ⚙️ 3 - 7 kW Ⓜ️ 79%



Mondo 2 Steel

MODELS AVAILABLE:



Mondo 1 Steel



Mondo 1S Soapstone



Mondo 2 Steel



Mondo 2S Soapstone

“ Lotus Jubilee 35 ”

A STUNNING STOVE WITH ENDLESS POTENTIAL

A truly outstanding stove, the Jubilee 35 combines an impressive 7kW heat output with a high efficiency of 82%. The stylish exterior holds a large combustion chamber that can accommodate logs of up to 50cm in length, and offers a breathtaking flame picture thanks to the expansive viewing window and powerful Airwash system. In addition, there is also a convenient concealed wood store compartment for quick and easy refuelling.

For added luxury, the choice of an extra baking oven compartment above the combustion chamber opens up a realm of possibilities for those looking to get the most out of their stove.

🔥 7 kW 🔁 4 - 10 kW 📊 82%

MODELS AVAILABLE:



Jubilee 35



Jubilee 35 with
Baking Oven









“ Lotus Prestige Integra ”

PRESTIGIOUS IN NAME AND NATURE

The unique Prestige Integra woodburning stove offers a slim, inset design that is perfect for the contemporary home.

Architect Kaare Sølvesten designed the stove with a minimalist style that can be adapted to suit your interior, or can become a compelling focal point in your home with its height and elegance.

The large glass door gives you a fantastic view of the flames. Beneath the stove door there is a practical fuel compartment that is integrated beautifully within the stove's elegant lines. The Prestige Integra is also available with the option of a heat storage stone of up to 90 kg to give you several hours of snug warmth.

🔥 5 kW

🔄 3 - 7 kW

ⓔ 80%



Prestige Integra

See notes on British and Irish building regulations in the Important Information Section on page 54





“ Lotus M2ST ”

A DISTINCTIVE STOVE WITH EXTRAORDINARY HEATING POTENTIAL

The Lotus M2ST is a stove that is sure to add instant impact and make a real style statement in your home.

The M2ST is equipped with an innovative integral heat storage system that retains heat during burning and then releases it gently for up to 14 hours after the fire has gone out. It also features the ability to control the amount of heat output to the room and that which is to be retained.

The vertical steel panels offer a clean contemporary form and allow the heat to radiate out from the storage cells into the room. The striking black steel is accented by the elegant stainless steel control levers and handle, making the M2ST the perfect combination of form and function, and an ultra-stylish solution for ensuring your home is always cosy and warm.

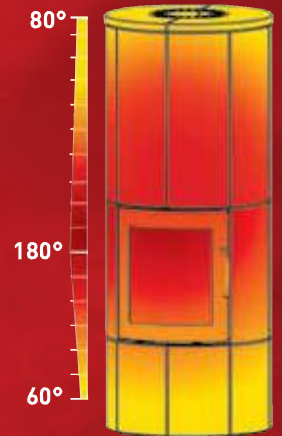

🔥 6 kW ↻ 4 - 10 kW Ⓜ 80%

WITH KINDLING, STOKING & THE ADDITION OF FIREWOOD 2-3 TIMES

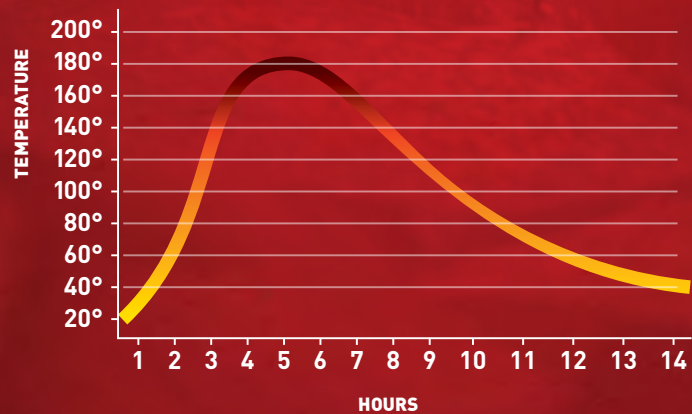

“Lotus Living”





“ We could have made a new stove, but instead we created something entirely different.. ”

Lotus Living – all the qualities of the woodburning stove now in an exquisite and luxurious design. Far from being merely a source of heat, this unique feature fire is a stylish mode of expression which sets a whole new standard for interior design. The Lotus Living is a free-standing fire with an elegant rounded form, exceptional flame picture and high efficiency heat output. The double-layered glass door ensures optimum insulation for better combustion in the firebox.

To extend your interior options, the Lotus Living can be installed with our anthracite grey Concrete Bench which creates an exciting contrast to the stoves subtle curves.

Lotus Living is available in a choice of 3 colours:

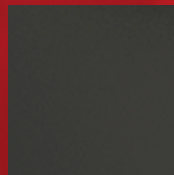

Phantom Grey



Ice Metallic

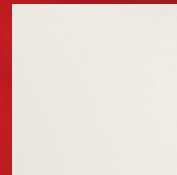

Alpina White



7 kW



3 - 9 kW



80.5%



Living in Phantom Grey



Living in Ice Metallic with Concrete Bench

“Lotus Living Base”



BREATHTAKING FLAME VIEWS

A totally unique combination of stove and plinth that adds instant appeal and a feature focal point in contemporary living spaces. The sturdy steel base provides convenient log storage and offers extra visual appeal by mirroring the beautiful curves of the Lotus Living fire.

Lotus Living & Base are available in three colours: Phantom Grey, Ice Metallic and Alpina White

🔥 7 kW 🔁 3 - 9 kW Ⓜ 80.5%



Living Base in Phantom Grey



Living Base in Phantom Grey



Living Base in Ice Metallic



Living Base in Alpina White

“ Lotus Living Cube ”



SUBTLY STUNNING

Lotus Living is all about contemporary tones and a sure sense of style. When combined with the Cube, the Lotus Living raises these to the highest levels as well as providing an attractive functional space in which to store your logs.

The Cube is colour matched to the fire in your choice of Phantom Grey, Ice Metallic and Alpina White.

This Cube is also available as a closed steel cube with your choice of a black glass or steel backing.

🔥 7 kW 🔁 3 - 9kW Ⓔ 80.5%



Living Cube in Phantom Grey



Living Cube in Ice Metallic



Living Cube in Alpina White

“Fireplace inserts - a world of possibilities”



Combining outstanding combustion technology with a fantastic view of the flames, Lotus fireplace inserts are an ideal choice if you are looking for a stylish centrepiece and high performance heating.

Lotus fireplace inserts are constructed according to the finest principles of craftsmanship with an exclusive and thoroughly thought-out design and finish that is in a class of its own. The elegant control lever integrates beautifully so nothing interrupts the inserts clean lines; a true testament to Kaare Sølvesten, the architect behind their simple yet refined design.

There are several sizes in the range from the portrait H700 to the widescreen H570W, each offered to expand your styling options and to suit the heating requirements of your home. Further styling options are available with a choice of either steel or Black Magic door and frame options. There is even a double-side model that allows you to enjoy the exciting flame visuals from two rooms at once!

Each of the insert fires is compatible with the optional warm air ducting kit that can distribute some of the fires heat into other rooms to really maximise the heating benefits from this stunning fire range.



H570W with Black Magic door & frame



“ Lotus H370 ”



DEPENDABLE DESIGN IN BLACK STEEL OR BLACK MAGIC

This fireplace insert is built according to the best principles of craftsmanship in an attractive and functional design. The elegant control lever integrates discreetly and the large glass door affords a fantastic view of the flames and creates a sense of cosiness and warmth



 6 kW  3 - 7kW  78%



H370 shown with Stovax Medium Black Log Holder

FIRE SIZE:



H370

“ Lotus H470 ”



ADVANCED ENGINEERING WITH BEAUTIFUL AESTHETICS

Presenting a stunning flame picture framed by either a Matt Black or Black Magic door with clean, minimalist styling, the 470 adds an impressive focal point to any living area. Burning at 84% efficiency, this 6kW fire is a high performance heating choice that combines beautiful aesthetics with advanced engineering. For optimal installation versatility, the 470's hinges can be positioned either side of the fire.

 6 kW  3 - 7kW  84%



H470 with Black Magic door & frame

FIRE SIZE:



H470

“ Lotus H470w ”



WOODBURNING IN WIDESCREEN

The H470W is a wide format woodburning insert with proportions that really accentuate the fire's stylish form and alluring flame picture. With ample heating capacity for larger living spaces and high efficiency technology to make the most of your fuel, this fire has the performance to match its aesthetic appeal.

 7 kW  3 - 10 kW  80.5%



H470W

FIRE SIZE:



H470W



MAXIMUM IMPACT

The H570 is a versatile fire that is available in an additional wide version to increase your interior options.

With the Lotus tunnel option, the elegant play of the flames can be enjoyed from two rooms at once! This eye-catching fire can be operated and refuelled from either side for complete convenience.

Also see images on page 30 and on the rear cover.

H570:  6 kW  3 - 8 kW  84%

H570W:  7 kW  4 - 11 kW  80.5%

H570T:  6 kW  4 - 9 kW  80.5%

“ Lotus H570 ”

Including Wide and Double Sided models



H570W

FIRE SIZES:



H570 (see rear cover)



H570W



The H570 is also available as a Double Sided 'Tunnel' model. (H570T)





“ Lotus H700 ”

THE PORTRAIT OF PERFECTION

Retaining the quality styling and innovative firebox characteristics that define the Lotus insert range, the H700 stands out with its distinctive portrait form.

Also see image on page 31.

 5 kW  3 - 7 kW  83%

FIRE SIZE:



H700



“ Lotus Beto ”

NORDIC FLAIR

Allowing 470 and 470W inset fires to be installed without a wall cavity or studwork, these stunning concrete surrounds are specifically designed to neatly house the fire - whilst adding a prominent centrepiece to your living area.

Coupling form with function, Beto surrounds can be upgraded with Lotus' optional PowerStones for long lasting heat. Possessing excellent thermal properties, PowerStones store heat during burning which is dissipated long after the fire has been extinguished – providing a great overnight heat source.

For greater installation versatility, both 470 and 470W fires can be selected with hinges to the right or left side of the fire, giving you even more options when choosing where to position the Beto.

H470:  6 kW  3 - 8 kW  84%

H470W:  7 kW  3 - 10 kW  80.5%



H470 Black Magic with Beto Surround



H470 with Beto Surround



H470W with Beto Surround

Note: The Beto surround is supplied in unfinished concrete which can be painted with breathable masonry paint to suit your decor. Images show the Beto painted white.

See notes on British and Irish building regulations in the Important Information Section on page 54

“Unique fires with unique possibilities...”



The Lotus Unico range offers breathtaking styling with impressive versatility, presenting a variety of single sided, two sided left corner, two sided right corner and three sided versions that offer numerous opportunities for a wide range of interiors.

Displaying all the hallmarks of a premium fire, the engineering behind the Unico's impressive construction is clearly visible, featuring an expansive firebox with large viewing windows kept clean by the powerful Airwash system, Lotus Unico fires offer a spectacular view of the flames as well as a generous 6kW heat output easily capable of warming spacious rooms.

Unico fires employ a number of design innovations that enhance both their functionality and ease of use, including a soft-close door that prevents slamming as well as an adjustable base for easier installation.



Unico 10 - Single Sided Fire

“ Lotus Unico 10 ”

CONTEMPORARY ELEGANCE

The single sided Unico 10 offers stunning flame visuals thanks to its advanced combustion systems. Elegant styling and subtle detailing make this exceptional fire an eye-catching centrepiece wherever it is placed.

🔥 6 kW 🔁 4 - 9 kW Ⓜ 80%



“Lotus Unico 11 & 12”



Unico 12

IMPRESSIVE VERSATILITY

Unico 11 and 12 models offer a corner installation, allowing the flame visuals to be appreciated from multiple angles thanks to the additional side window. Choose the Unico 11 for a right corner window or the Unico 12 for a left corner window. Both models feature all the benefits of the Unico range detailed on page 44.

 6 kW  4 - 9 kW  80%



FIRE SIZE:



Unico 11 - Two Sided
Right Corner Fire



Unico 12 - Two Sided
Left Corner Fire

“ Lotus
Unico 13 ”

Unico 13

PANORAMIC FLAME VISUALS

The Unico 13 features three viewing windows for a panoramic view of the fire and truly unique installation possibilities. Sharing all the benefits of the Unico range detailed on page 44, this three-sided fire incorporates both Airwash and Cleanburn systems as well as producing a powerful 6kW heat output.

 6 kW  4 - 9 kW  80%



FIRE SIZE:



Unico 13 - Three Sided Fire

“Technical Information - Stoves”

Sola

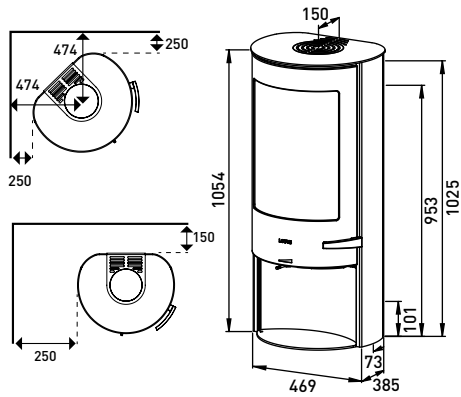

Weight: 127kg

Liva 5

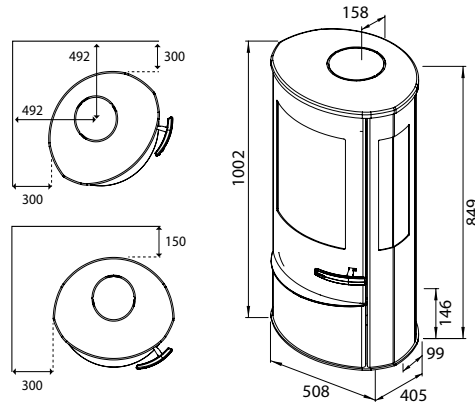

Weight: 134kg

Liva 6

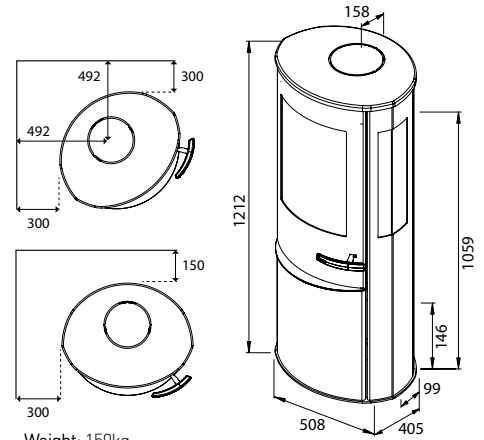

Weight: 150kg

Liva 7G

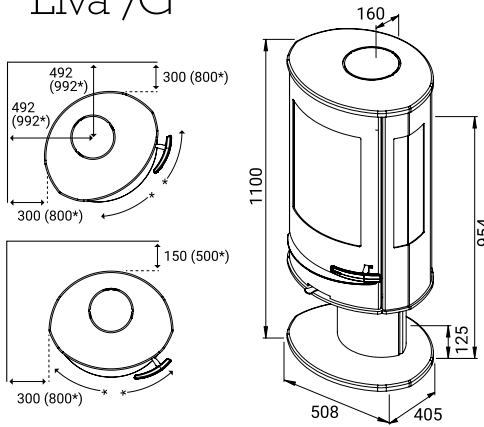

Weight: 157kg

* Distance to combustible material is increased if installed as a rotating stove

Liva 8

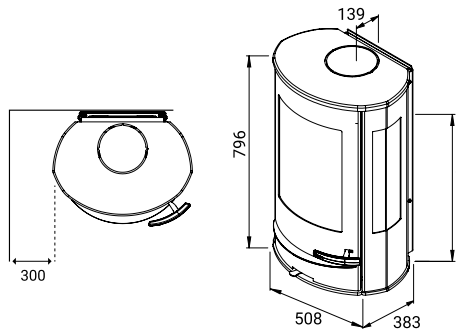

Weight: 116kg

Mira 3 & 4

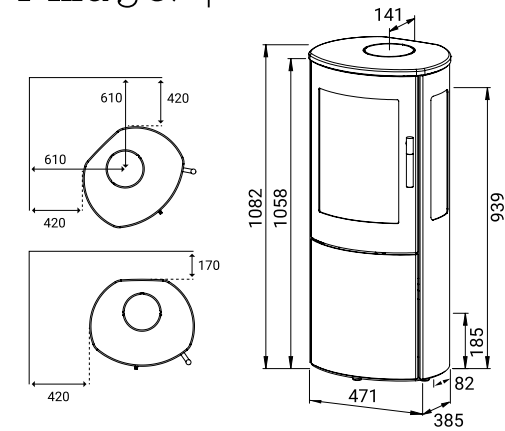

Weight: Mira 3: 117kg / Mira 4: 117kg

Mira 7

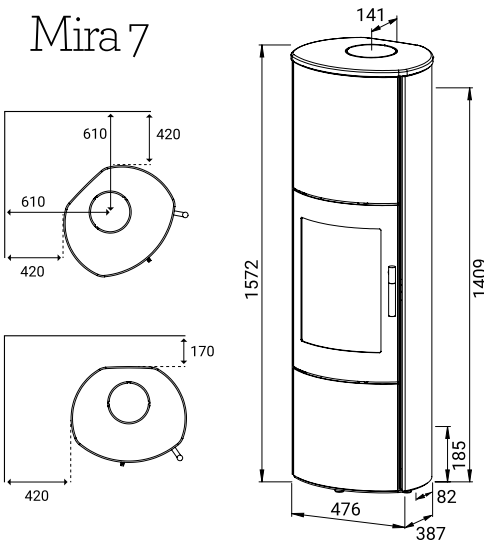

Weight: 136kg

Prio 5 & 6

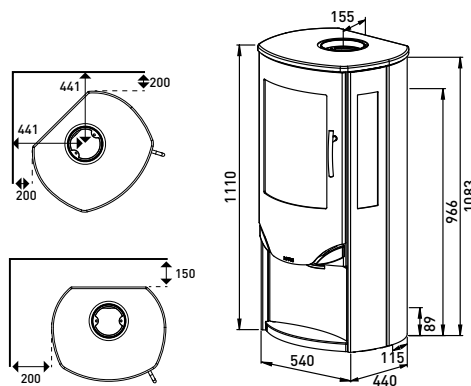

Weight: Prio 5 & 6: 164kg / Prio 5S: 239kg / Prio 6S: 226kg

Mondo 1 & 2

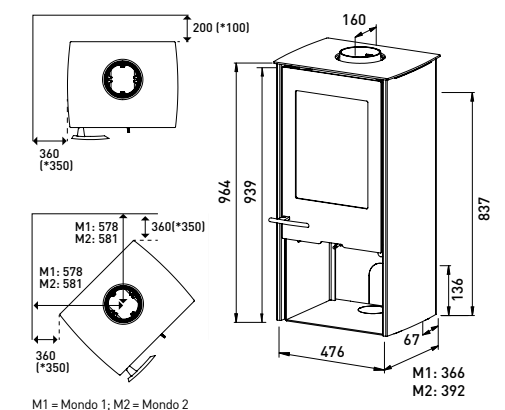

M1 = Mondo 1; M2 = Mondo 2

Weight: Mondo 1: 108kg / Mondo 1S: 159kg

Weight: Mondo 2: 109kg / Mondo 2S: 159kg

Jubilee 35

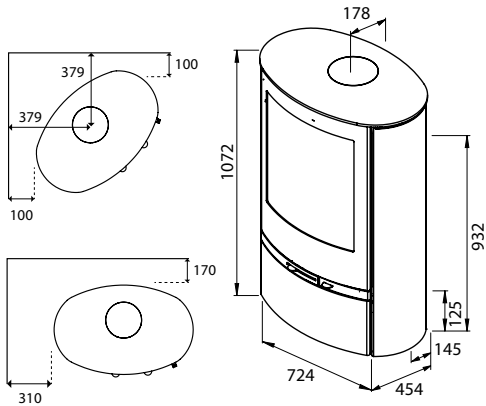

Weight: 192kg

Jubilee 35 with Baking Oven

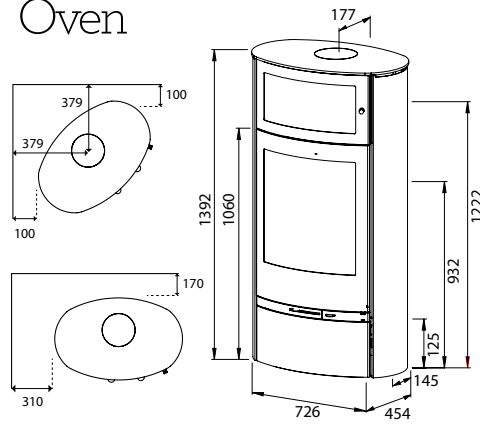

Weight: 236kg

Prestige Integra

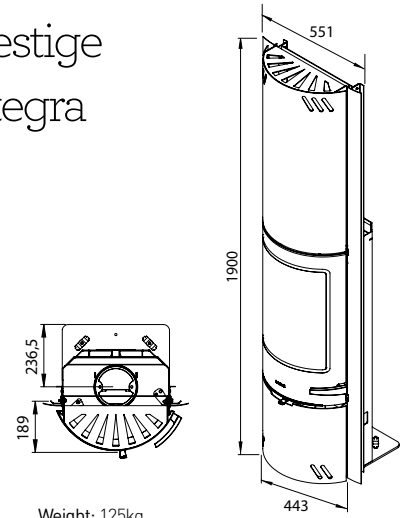

Weight: 125kg

M2ST

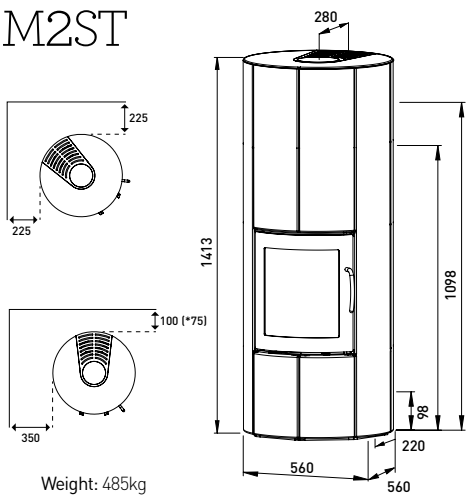

Weight: 485kg

Living Base

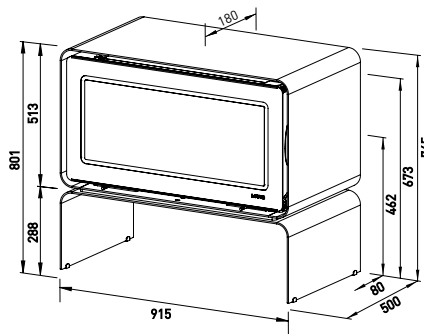

Weight: 190kg

Living Cube

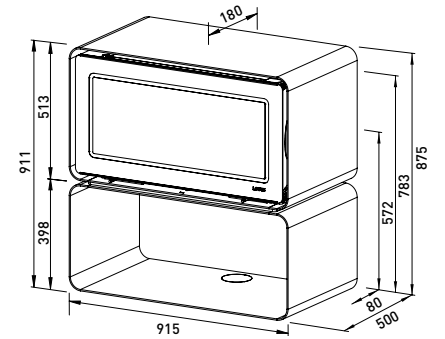

Weight: 211kg

Living Bench

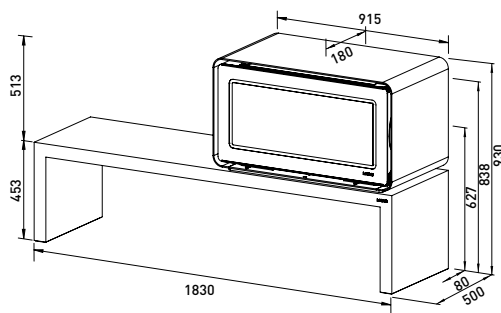

Weight: 271kg

Living Distance to Combustibles

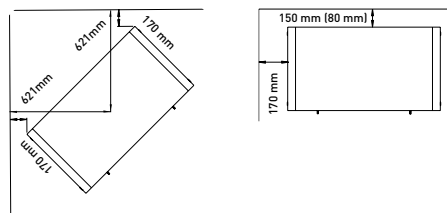

Measurements in brackets are the distance from Wall to Stove with an insulated flue.

“Technical Information - Cassette Fires”

Unico 10

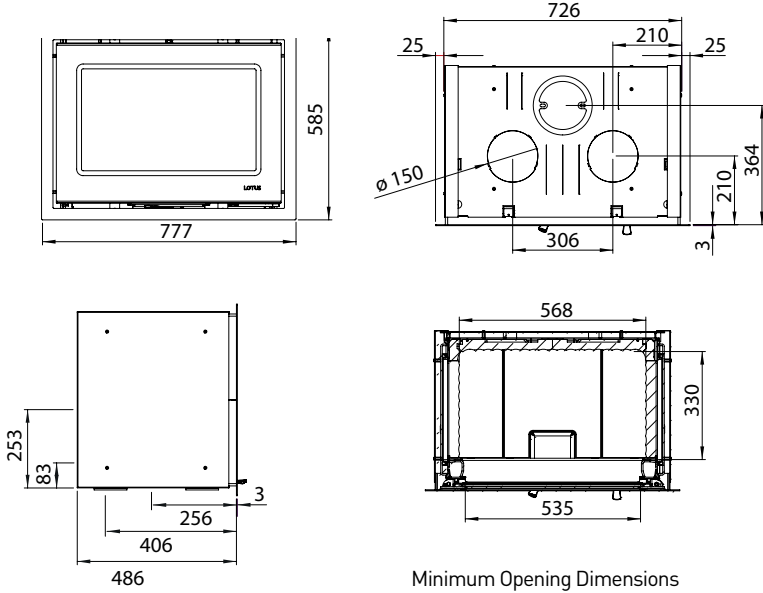

Minimum Opening Dimensions

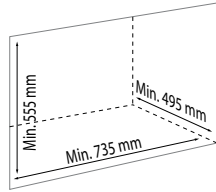

Weight: 122kg

Unico 11

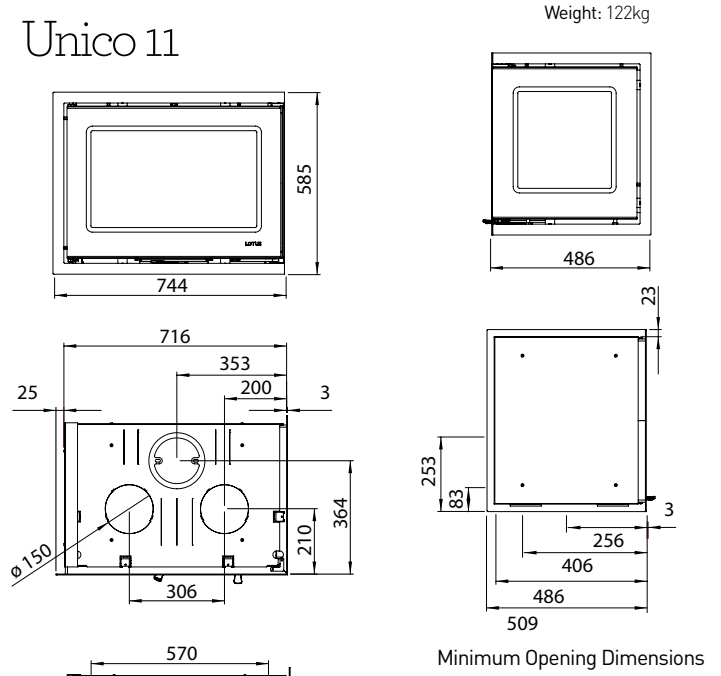

Minimum Opening Dimensions

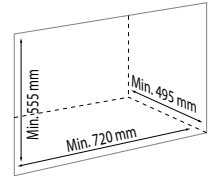

Weight: 122kg

Unico 12

Weight: 122kg

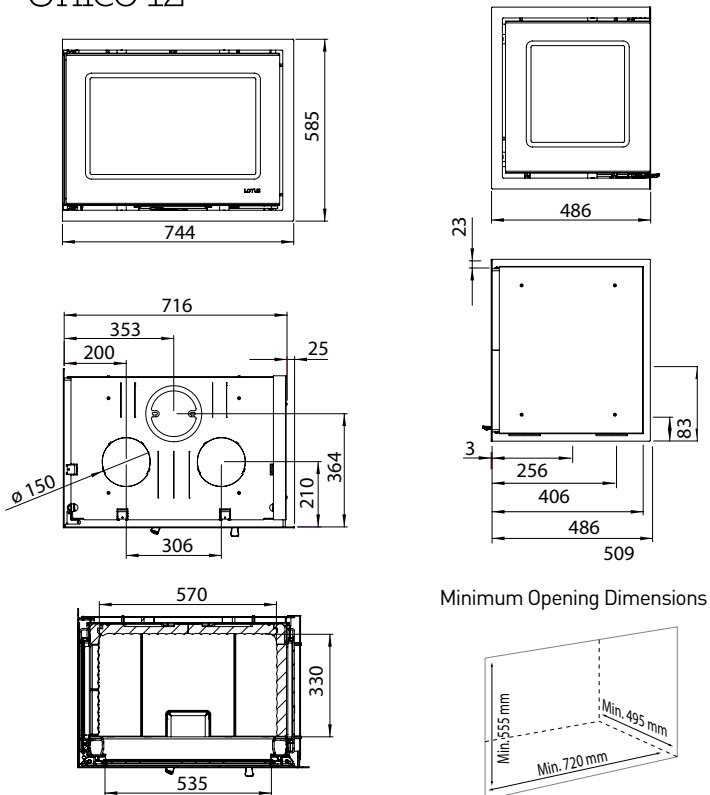

Minimum Opening Dimensions

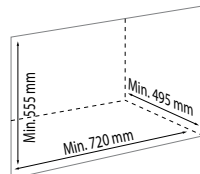

Unico 13

Weight: 122kg

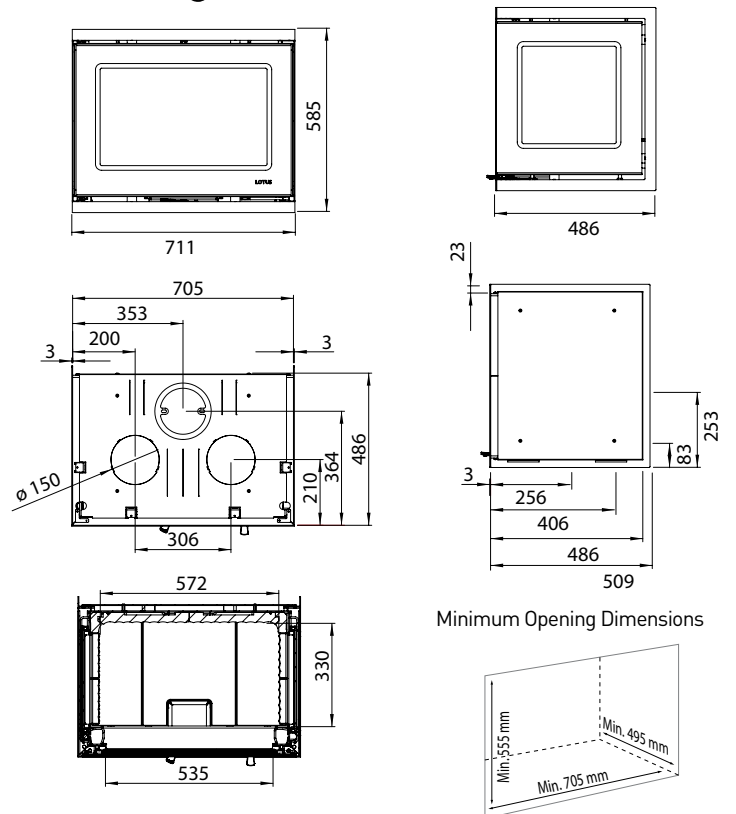

Minimum Opening Dimensions

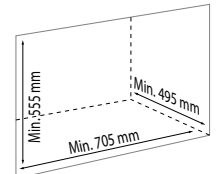

Fireplace Insert Dimensions

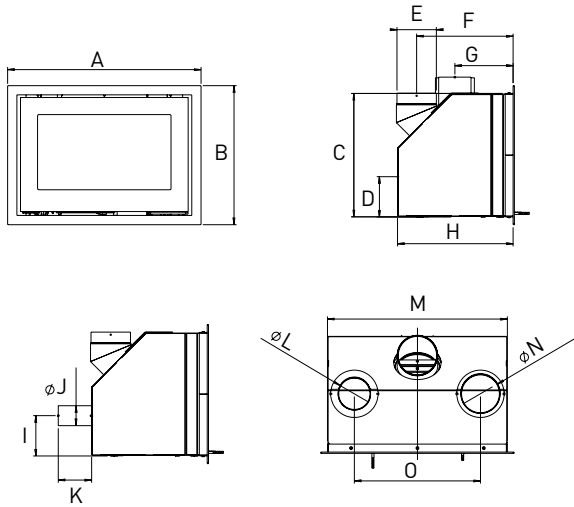

	H370 Petite	H470	H470W	H570	H570W	H570T (Double Sided)	H700
	6kW	6kW	7kW	6kW	7kW	6kW	5kW
	3 - 7kW	3 - 7kW	3 - 10kW	3 - 8kW	4 - 11kW	4-9kW	3 - 7kW
	78%	84%	80.5%	84%	80.5%	80.5%	83%
	30 -120m ²	30 -120m ²	30 -130m ²	30 -120m ²	30 - 130m ²	30 -120m ²	30 -110m ²
	87kg	95kg	120kg	111kg	154kg	155kg	96kg

Dimensions (mm)

A	736	736	948	756	1088	756	515
B	529	529	529	654	654	654	784
C	470	470	470	575	575	575	705
D	154	154	154	154	154	-	154
E	150	150	150	150	150	150	150
F	265	365	365	365	365	295	365
G	122	221	222	222	222	-	219
H	340	440	440	440	440	590	440
I	154	154	154	154	154	-	154
J	76	76	76	76	76	76	76
K	127	127	127	127	127	-	127
L	-	123	148	148	148	-	148
M	685	685	897	685	1017	685	450
N	-	148	148	148	148	-	148
O	-	480	510	480	600	-	230

Minimum Opening Dimensions (mm)

P	480	480	480	585	585	585	715
Q	350	450	450	450	450	590	450
R	695	695	907	695	1027	695	452

Minimum Opening Dimensions

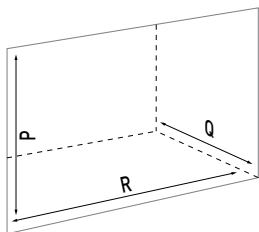

Key

- Nominal Heat Output
- Heat Output Range
- Efficiency
- Room Size
- Weight

Distance to combustible material is measured when using insulated flue pipe from the top of the product.

Beto 470 Surround

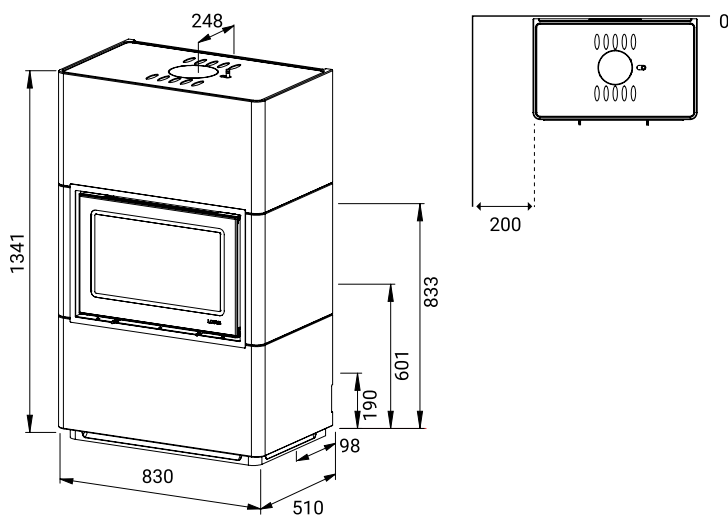

Beto 470w Surround

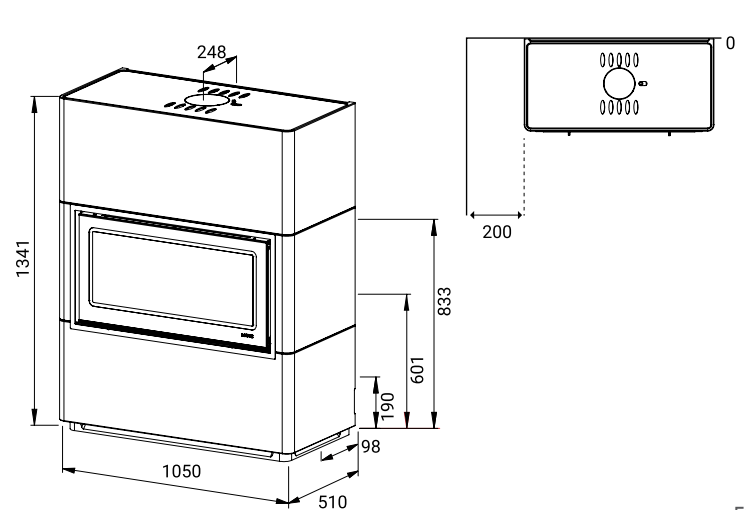

“Further Information”

PRODUCT IMPROVEMENT & WARRANTY

Lotus pursue a policy of constant product improvement. Products supplied may therefore differ in specification from those illustrated or described in this brochure, and you should always check the final specification with your Lotus retailer.



Your Lotus Expert Retailer will provide you with a Two Year Warranty for your new woodburning stove or fire. This can then be extended to a Five Year Warranty provided your stove is registered with Lotus within one month of the later of the purchase date or installation date. Accordingly, the start date for the warranty period is the date of purchase. During the registration process the Expert Retailer details will be required for your Extended Warranty to be activated. Please note, this warranty excludes certain consumable parts and is dependant on your appliance being serviced by an appropriately qualified person 12 months after installation and annually thereafter. Stoves purchased outside of Lotus' Expert Retailer Network will carry a standard 1 Year Warranty. Full details of this warranty is set out to view on our website at www.lotusfires.com.

IMPORTANT INFORMATION

Please note that the installations shown within this brochure may not conform to British and Irish building regulations. Please consult with a qualified professional installer (HETAS registered in the United Kingdom) for expert advice including the requirement for a hearth in your home.

We recommend that a HETAS approved installer should undertake a site survey prior to purchase and it is a requirement that any Lotus stove or fire should be installed by an appropriately qualified HETAS approved installer.

All fires and stoves consume air as they burn. To comply with Building Regulations (Document J) you may need to install a fixed air vent to ensure adequate ventilation. A room vent is not normally required when the air permeability is greater than 5.0m³/hr/m². Your Lotus retailer or HETAS installer will be able to advise on this. You can also download detailed installation instructions prior to purchase from www.lotusfires.com. Furthermore, by law all installations also require a Carbon Monoxide Monitor be present.

Please note that all parts of these stoves, particularly the glass panel in the door, become extremely hot during operation and can result in serious injury and burns if touched. It is therefore recommended that a fireguard complying with BS 8423:2002 is used in the presence of young children, the elderly or infirm.

CARE OF YOUR STOVE OR FIRE



To help you get the best performance from your stove or fireplace and keep it in good condition, Stovax (Lotus' distributor in the UK and Republic of Ireland) offers a wide range of cleaning and maintenance products. Stovax also supplies a wide variety of high quality fireplace accessories such as contemporary steel log holders. Your Lotus retailer will be able to give you full details or you can view the complete range at Stovax's website - www.stovax.com.



STOVAX PROFESSIONAL XQ™ STOVE AND FIREPLACE CHIMNEY SYSTEMS

Lotus recommends the Stovax comprehensive range of stove and fireplace chimney systems, the Stovax Professional XQ™ collection.

Crafted from 304L grade stainless steel for a durable outer finish, the fully sealed components offer water tight protection for the insulation within.



With innovative decorative options, the ability to specify a colour for your system, and with a host of technical advancements such as its Twist-Lock system, the Stovax Professional XQ™ range provides an attractive, versatile and reliable solution for your flue system. Furthermore, the Stovax Professional XQ™ range carries a 10 Year Extended Warranty offering complete peace of mind.

For further information or to request a brochure, simply contact your local retailer or visit www.stovax.com.







H570

United Kingdom & Republic of Ireland
distributors for Lotus:

Stovax Limited
Falcon Road, Sowton Industrial Estate,
Exeter, Devon EX2 7LF

UK Trade Sales tel: 01392 474000
ROI Trade Sales tel: 00 44 1392 261990

Fax: 01392 219932

E-mail: lotus@stovax.com

www.lotusfires.com



To view & download our complete
range of brochures, simply scan this
code or visit www.stovax.com

Your local Lotus retailer:

£2.00

LOTUS1116

